

# LG12864H-DW

128 x 64 dots + white led backlight

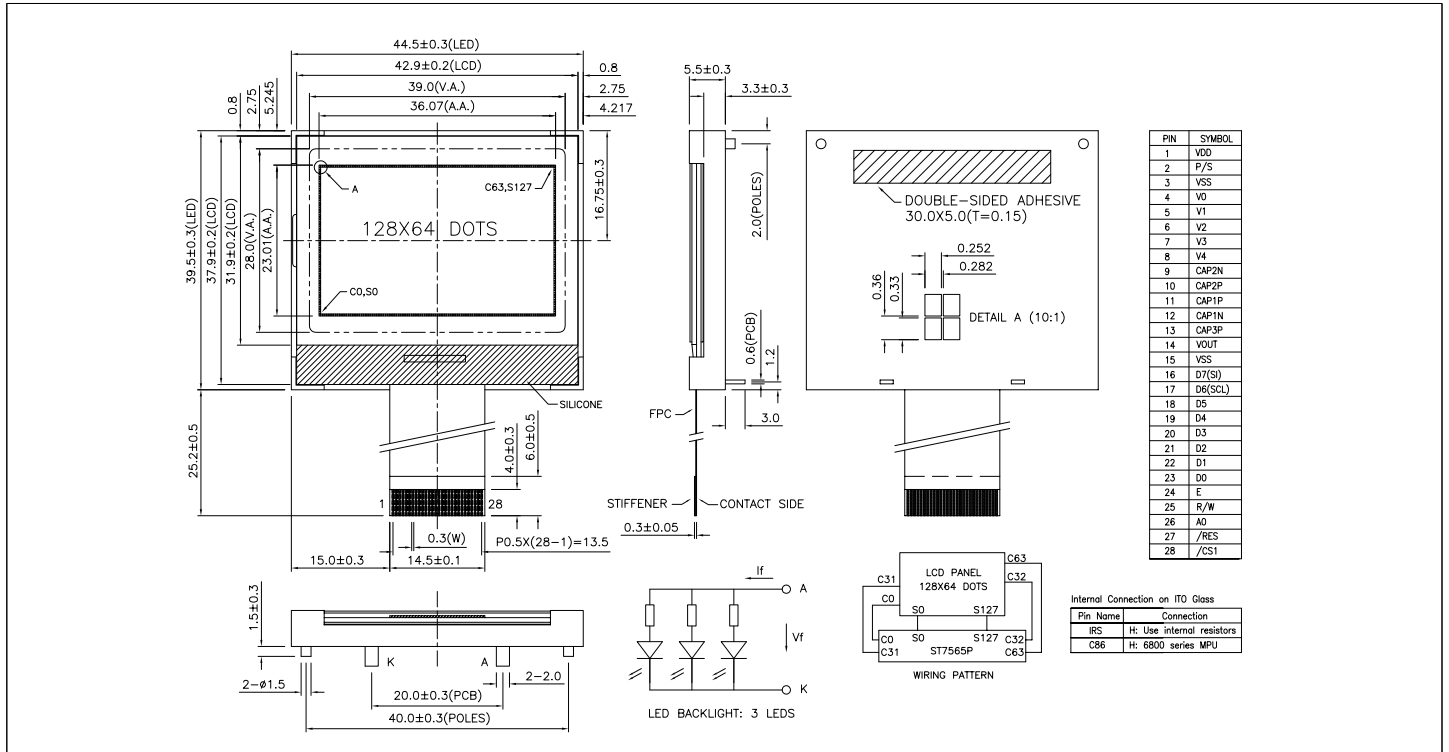

## ABSOLUTE MAXIMUM RATINGS

Item	Symbol	Min.	Max.	Unit
Supply Voltage(Logic)	V <sub>DD</sub> - V <sub>SS</sub>	-0.3	3.6	V
Supply Voltage(LCD)	V <sub>OUT</sub> - V <sub>SS</sub>	-0.3	14.5	V
Input Voltage	V <sub>I</sub>	-0.3	V <sub>DD</sub> + 0.3	V
Operating Temp.	T <sub>opr</sub>	-20	70	°C
Storage Temp.	T <sub>stg</sub>	-30	80	°C

## MECHANICAL DATA

Item	Nominal Dimensions	Unit
Module Size ( W x H x T )	44.5 x 39.5 x 8.5	mm
Viewing Area ( W x H )	39.0 x 28.0	mm
Dot Pitch ( W x H )	0.282 x 0.36	mm
Dot Size ( W x H )	0.252 x 0.33	mm
Weight	Approx. 14	g

## ELECTRICAL CHARACTERISTICS ( V<sub>DD</sub>=3V to 3.3V )

Item	Symbol	Test Condition	Min.	Typ.	Max.	Unit
Input High Voltage	V <sub>IH</sub>	--	0.8V <sub>DD</sub>	--	V <sub>DD</sub>	V
Input Low Voltage	V <sub>IL</sub>	--	0	--	0.2V <sub>DD</sub>	V
Output High Voltage	V <sub>OH</sub>	I <sub>OH</sub> = -0.1mA	0.8V <sub>DD</sub>	--	V <sub>DD</sub>	V
Output Low Voltage	V <sub>OL</sub>	I <sub>OL</sub> = 0.1mA	0	--	0.2V <sub>DD</sub>	V
Supply Current	I <sub>DD</sub>	V <sub>DD</sub> = 3 to 3.3V	--	0.4	0.8	mA
LCD Driving Voltage	V <sub>0</sub> - V <sub>SS</sub>	T <sub>a</sub> = 25°C	--	9.9	--	V

## PIN CONNECTIONS

Pin	Symbol	Level	Function
1	V <sub>DD</sub>	3V-3.3V	Power supply for logic and booster
2	P/S	H/L	H: Parallel mode L: Serial mode
3	V <sub>SS</sub>	0V	GND
4-8	V0-V4	--	Power supply for LCD drive
9	CAP2N	--	Capacitor 2 negative connection
10	CAP2P	--	Capacitor 2 positive connection
11	CAP1P	--	Capacitor 1 positive connection
12	CAP1N	--	Capacitor 1 negative connection
13	CAP3P	--	Capacitor 3 positive connection
14	V <sub>OUT</sub>	--	DC/DC voltage converter output
15	V <sub>SS</sub>	0V	GND
16	D7(SI)	H/L	P/S=H: D0 to D7 are 8-bit data bus.
17	D6(SCL)	H/L	P/S=L: D6 is serial clock input;
18-23	D5-D0	H/L	D7 is serial data input.
24	E	H,H>L	Enable signal
25	R/W	H/L	H: Read L: Write
26	A0	H/L	H: Display data L: Instruction code
27	/RES	L	Reset signal. Active "L".
28	/CS1	L	Chip selection signal. Active "L".

## BLOCK DIAGRAM

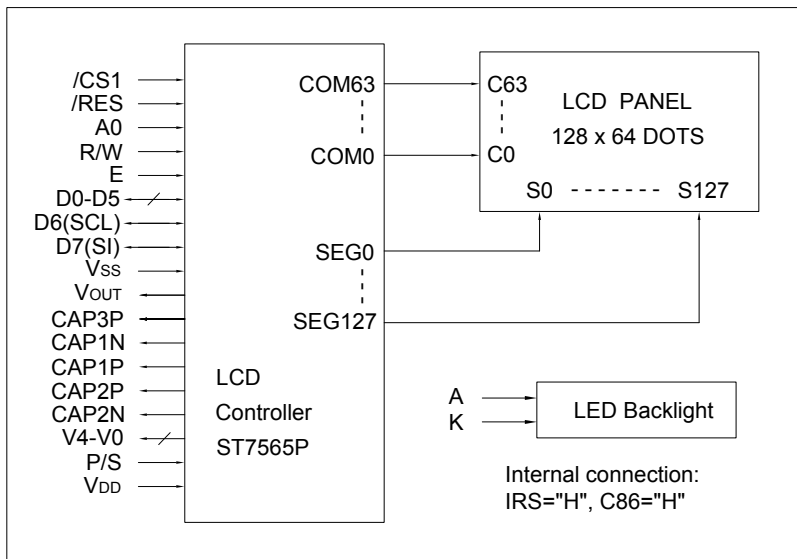

## LED BACKLIGHT SPECIFICATIONS (T<sub>a</sub>=25°C)

Item	Symbol	Typ.	Max.	Unit
Forward Voltage	V <sub>f</sub>	2.9	3.1	V
Forward Current	I <sub>f</sub>	20	--	mA
LED Color		White		