

ABSOLUTE MAXIMUM RATINGS

Item	Symbol	Min.	Max.	Unit
Supply Voltage(Logic)	V _{DD} - V _{SS}	-0.3	4.0	V
Supply Voltage(LCD)	V _{LCD} - V _{SS}	-0.3	17.0	V
Input Voltage	V _I	-0.3	V _{DD} + 0.5	V
Operating Temp.	T _{opr}	-20	70	°C
Storage Temp.	T _{stg}	-30	80	°C

MECHANICAL DATA

Item	Nominal Dimensions	Unit
Module Size (W x H x T)	98.7 x 67.7 x 12.0	mm
Viewing Area (W x H)	91.0 x 51.0	mm
Dot Pitch (W x H)	0.35 x 0.35	mm
Dot Size (W x H)	0.325 x 0.325	mm
Weight	Approx. 75	g

ELECTRICAL CHARACTERISTICS (V_{DD}=3V±0.3V)

Item	Symbol	Test Condition	Min.	Typ.	Max.	Unit
Input High Voltage	V _{IH}	--	0.8V _{DD}	--	V _{DD}	V
Input Low Voltage	V _{IL}	--	0	--	0.2V _{DD}	V
Output High Voltage	V _{OH}	--	0.8V _{DD}	--	V _{DD}	V
Output Low Voltage	V _{OL}	--	0	--	0.2V _{DD}	V
Supply Current	I _{DD}	V _{DD} = 3.0V	--	1.0	1.5	mA
LCD Driving Voltage	V _{LCD} -V _{SS}	T _a =25°C	--	15.2	--	V

PIN CONNECTIONS

Pin	Symbol	Level	Function
1	VB1-	--	LCD bias voltage
2	VB1+	--	LCD bias voltage
3	VB0-	--	LCD bias voltage
4	VB0+	--	LCD bias voltage
5	VLCD	--	LCD driving voltage. V _{LCD} is generated internally by UC1608.
6	VBIAS	--	Reference voltage to generate lcd driving voltage. V _{BIAS} is used for LCD contrast fine turning.
7	VSS	0V	GND
8	VDD	2.7-3.3V	Power supply for logic and booster
9-16	D7-D0	H/L	Data bus
17	WR1	H/L	/RD for 80 MPU, E for 68 MPU
18	WR0	H/L	/WR for 80 MPU, R/W for 68 MPU
19	CD	H/L	H:Display data L:Instruction code
20	RST	L	Reset signal. Active "L".
21	CS	H	Chip selection signal. Active "H".
22	BM0	H/L	Bus mode selection
23	BM1	H/L	

BLOCK DIAGRAM

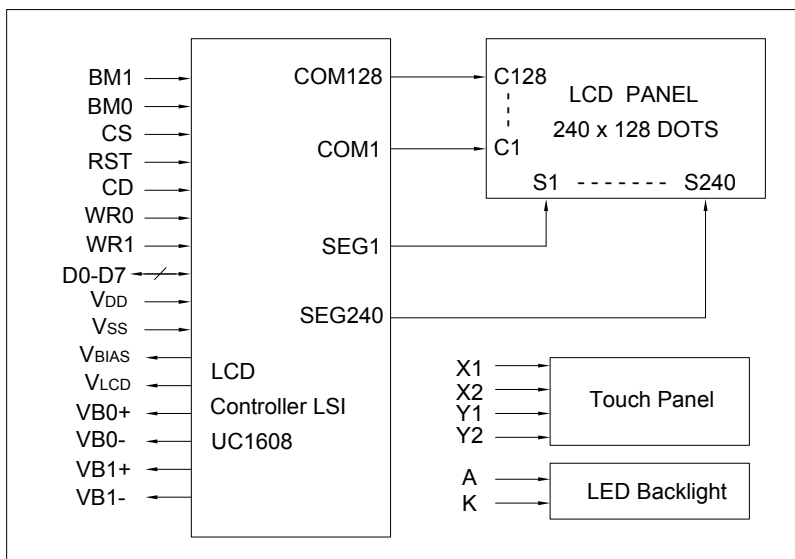

LED BACKLIGHT SPECIFICATIONS (T_a=25°C)

Item	Symbol	Typ.	Max.	Unit
Forward Voltage	V _f	3.1	3.3	V
Forward Current	I _f	90	--	mA
LED Color		White		