

ABSOLUTE MAXIMUM RATINGS

Item	Symbol	Min.	Max.	Unit
Supply Voltage(L logic)	$V_{DD} - V_{SS}$	-0.3	7.0	V
Supply Voltage(LCD)	$V_{DD} - V_O$	-0.3	13.5	V
Input Voltage	V_I	-0.3	$V_{DD} + 0.3$	V
Operating Temp.	T_{opr}	-20	70	°C
Storage Temp.	T_{stg}	-30	80	°C

MECHANICAL DATA

Item	Nominal Dimensions	Unit
Module Size (W x H x T)	98.0 x 50.0 x 13.5	mm
Viewing Area (W x H)	76.0 x 26.0	mm
Dot Pitch (W x H)	0.60 x 0.60	mm
Dot Size (W x H)	0.55 x 0.55	mm
Weight	Approx. 65	g

ELECTRICAL CHARACTERISTICS ($V_{DD}=5V \pm 0.25V$)

Item	Symbol	Test Condition	Min.	Typ.	Max.	Unit
Input High Voltage	V_{IH}	--	0.7 V_{DD}	--	V_{DD}	V
Input Low Voltage	V_{IL}	--	0	--	0.25 V_{DD}	V
Output High Voltage	V_{OH}	--	$V_{DD}-0.3$	--	V_{DD}	V
Output Low Voltage	V_{OL}	--	0	--	0.3	V
Supply Current	I_{DD}	$V_{DD} = 5.0V$	--	1.2	2.0	mA
LCD Driving Voltage	$V_{DD} - V_O$	$T_a=25^\circ C$	--	7.5	--	V

PIN CONNECTIONS

Pin	Symbol	Level	Function
1	V_{SS}	0V	GND
2	V_{DD}	+5V	Power supply for logic
3	V_O	--	Operating voltage for LCD
4	A0	H/L	H : Data L : Instruction code
5	R/W	H/L	H : Read L : Write
6	E1	H,H>L	Enable signal 1
7	E2	H,H>L	Enable signal 2
8	/RST or NC	--	J3 close: Reset signal. Active "L". J3 open: No connection
9	DB0	H/L	Data bus
10	DB1	H/L	
11	DB2	H/L	
12	DB3	H/L	
13	DB4	H/L	
14	DB5	H/L	
15	DB6	H/L	
16	DB7	H/L	
17	LEDA	+5V	Power supply for LED backlight
18	LEDK	0V	

BLOCK DIAGRAM

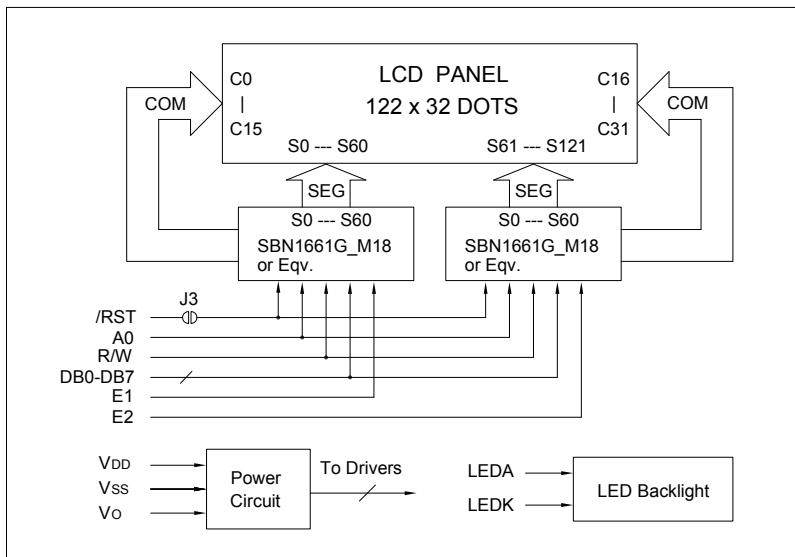

LED BACKLIGHT SPECIFICATIONS ($T_a=25^\circ C$)

Item	Symbol	Typ.	Max.	Unit
Forward Voltage	V_f	4.1	4.3	V
Forward Current	I_f	220	--	mA
Emission Wave Length	λ_p	568	--	nm