

### ABSOLUTE MAXIMUM RATINGS

Item	Symbol	Min.	Max.	Unit
Supply Voltage(Logic)	V <sub>DD</sub> - V <sub>SS</sub>	-0.3	6.0	V
Supply Voltage(LCD)	V <sub>DD</sub> - V <sub>OUT</sub>	-0.3	12.0	V
Input Voltage	V <sub>I</sub>	-0.3	V <sub>DD</sub> + 0.3	V
Operating Temp.	T <sub>opr</sub>	-20	70	°C
Storage Temp.	T <sub>stg</sub>	-30	80	°C

### MECHANICAL DATA

Item	Nominal Dimensions	Unit
Module Size ( W x H x T )	89.7 x 49.8 x 11.8	mm
Viewing Area ( W x H )	66.8 x 35.5	mm
Dot Pitch ( W x H )	0.50 x 0.50	mm
Dot Size ( W x H )	0.48 x 0.48	mm
Weight	Approx. 40	g

### ELECTRICAL CHARACTERISTICS ( V<sub>DD</sub>=3V to 5V )

Item	Symbol	Test Condition	Min.	Typ.	Max.	Unit
Input High Voltage	V <sub>IH</sub>	--	0.8V <sub>DD</sub>	--	V <sub>DD</sub>	V
Input Low Voltage	V <sub>IL</sub>	--	0	--	0.2V <sub>DD</sub>	V
Output High Voltage	V <sub>OH</sub>	I <sub>OH</sub> = -0.1mA	0.8V <sub>DD</sub>	--	V <sub>DD</sub>	V
Output Low Voltage	V <sub>OL</sub>	I <sub>OL</sub> = 0.1mA	0	--	0.2V <sub>DD</sub>	V
Supply Current	I <sub>DD</sub>	V <sub>DD</sub> = 5.0V	--	0.3	1.0	mA
		V <sub>DD</sub> = 3.0V	--	0.6	1.5	mA
LCD Driving Voltage	V <sub>DD</sub> - V <sub>5</sub>	T <sub>a</sub> =25°C	--	8.7	--	V

### PIN CONNECTIONS

Pin	Symbol	Level	Function
1	NC	--	No connection
2	/CS1	L	Chip selection signa. Active "L".
3	/RES	L	Reset signal. Active "L".
4	A0	H/L	H : Data L : Instruction code
5	/WR(R/W)	H/L	/WR for 80 MPU, R/W for 68 MPU
6	/RD(E)	H/L	/RD for 80 MPU, E for 68 MPU
7-14	D0-D7	H/L	Data bus
15	V <sub>DD</sub>	3V-5V	Power supply for logic and booster
16	V <sub>SS</sub>	0V	GND
17	V <sub>OUT</sub>	--	DC/DC voltage converter output
18	CAP3N	--	Capacitor 3 negative connection
19	CAP1P	--	Capacitor 1 positive connection
20	CAP1N	--	Capacitor 1 negative connection
21	CAP2N	--	Capacitor 2 negative connection
22	CAP2P	--	Capacitor 2 positive connection
23-27	V1-V5	--	Power supply for LCD drive
28	VR	--	Output voltage adjustment terminal
29	C86	H/L	H: 68 series MPU L: 80 series MPU
30	IRS	H/L	H: Use internal resistors for booster L: Use external resistors for booster

### BLOCK DIAGRAM

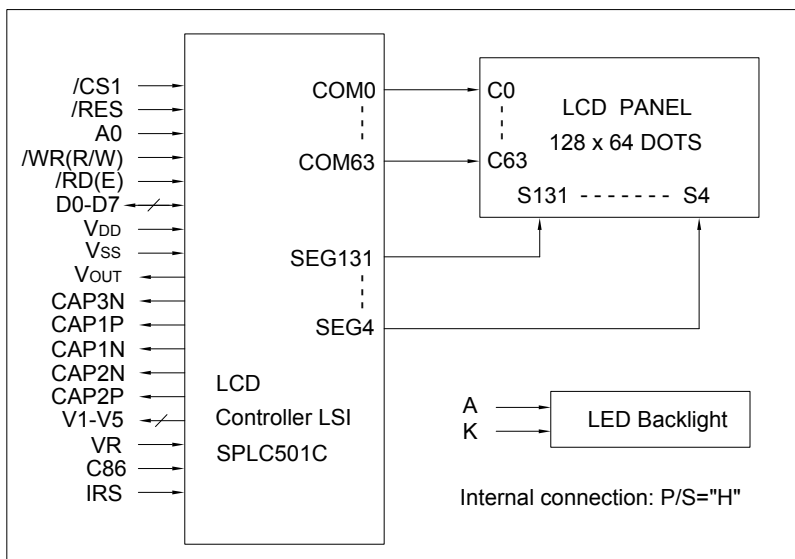

### LED BACKLIGHT SPECIFICATIONS (T<sub>a</sub>=25°C)

Item	Symbol	Typ.	Max.	Unit
Forward Voltage	V <sub>f</sub>	4.1	4.3	V
Forward Current	I <sub>f</sub>	140	--	mA
Emission Wave Length	λ <sub>p</sub>	568	--	nm