

LG120321-LY 120 x 32 dots + yellow green led backlight

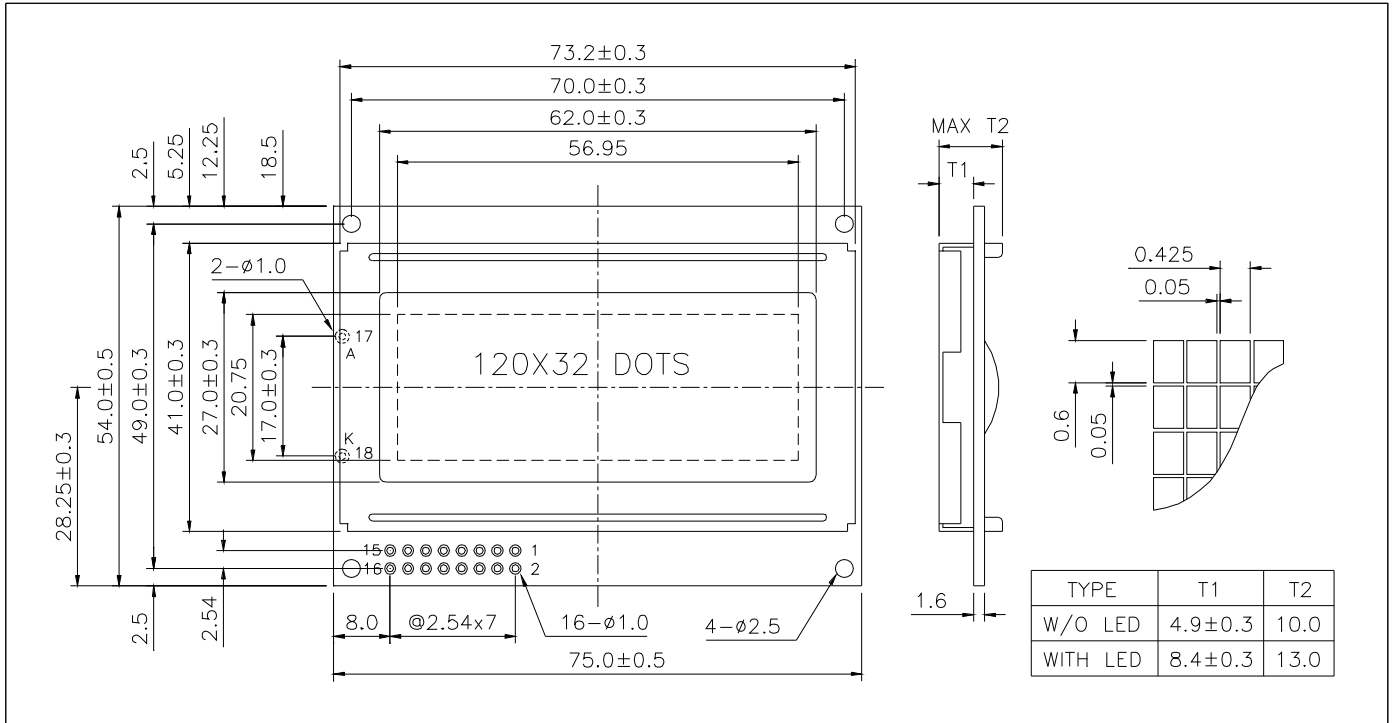

ABSOLUTE MAXIMUM RATINGS

Item	Symbol	Min.	Max.	Unit
Supply Voltage(Logic)	V _{DD} - V _{SS}	-0.3	7.0	V
Supply Voltage(LCD)	V _{DD} - V _O	-0.3	13.5	V
Input Voltage	V _I	-0.3	V _{DD} + 0.3	V
Operating Temp.	T _{opr}	-20	70	°C
Storage Temp.	T _{stg}	-30	80	°C

MECHANICAL DATA

Item	Nominal Dimensions	Unit
Module Size (W x H x T)	75.0 x 54.0 x 10.0/13.0	mm
Viewing Area (W x H)	62.0 x 27.0	mm
Dot Pitch (W x H)	0.475 x 0.65	mm
Dot Size (W x H)	0.425 x 0.6	mm
Weight (Reflective/LED)	Approx. 40/60	g

ELECTRICAL CHARACTERISTICS (V_{DD}=5V±0.25V)

Item	Symbol	Test Condition	Min.	Typ.	Max.	Unit
Input High Voltage	V _{IH}	--	0.7V _{DD}	--	V _{DD}	V
Input Low Voltage	V _{IL}	--	0	--	0.25V _{DD}	V
Output High Voltage	V _{OH}	--	V _{DD} -0.3	--	V _{DD}	V
Output Low Voltage	V _{OL}	--	0	--	0.3	V
Supply Current	I _{DD}	V _{DD} = 5.0V	--	1.2	2.0	mA
LCD Driving Voltage	V _{DD} - V _O	T _a =25°C	--	7.5	--	V

PIN CONNECTIONS

Pin	Symbol	Level	Function
1	V _{SS}	0V	GND
2	V _{DD}	+5V	Power supply for logic
3	V _O	--	Operating voltage for LCD
4	A0	H/L	H : Data L : Instruction code
5	R/W	H/L	H : Read L : Write
6	E1	H,H >L	Enable signal 1
7	E2	H,H >L	Enable signal 2
8	NC or /RST	--	J3 open: No connection J3 close: Reset signal, active "L"
9	DB0	H/L	Data Bus Line
10	DB1	H/L	
11	DB2	H/L	
12	DB3	H/L	
13	DB4	H/L	
14	DB5	H/L	
15	DB6	H/L	
16	DB7	H/L	
17	LEDA	+4.1V	Power supply for LED backlight
18	LEDK	0V	

BLOCK DIAGRAM

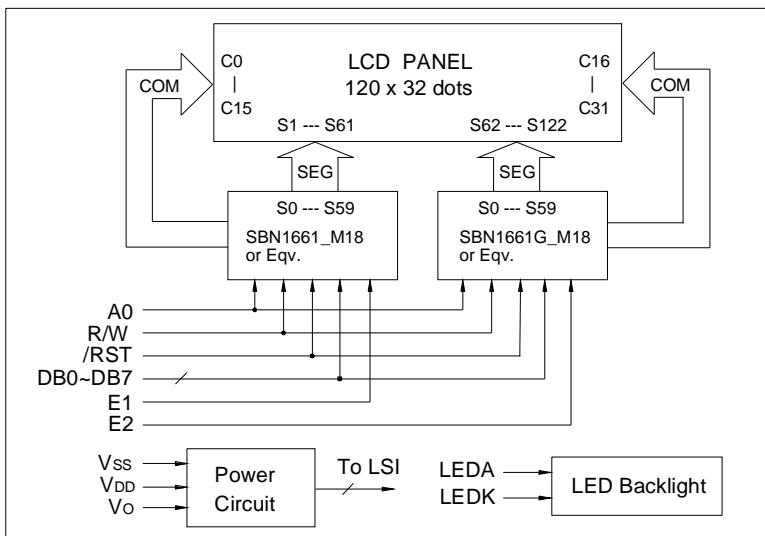

LED BACKLIGHT SPECIFICATIONS (T_a=25°C)

Item	Symbol	Typ.	Max.	Unit
Forward Voltage	V _f	4.1	4.3	V
Forward Current	I _f	200	--	mA
Emission Wave Length	λ _p	568	--	nm