

LG12864E-DW

128 x 64 dots + white led backlight

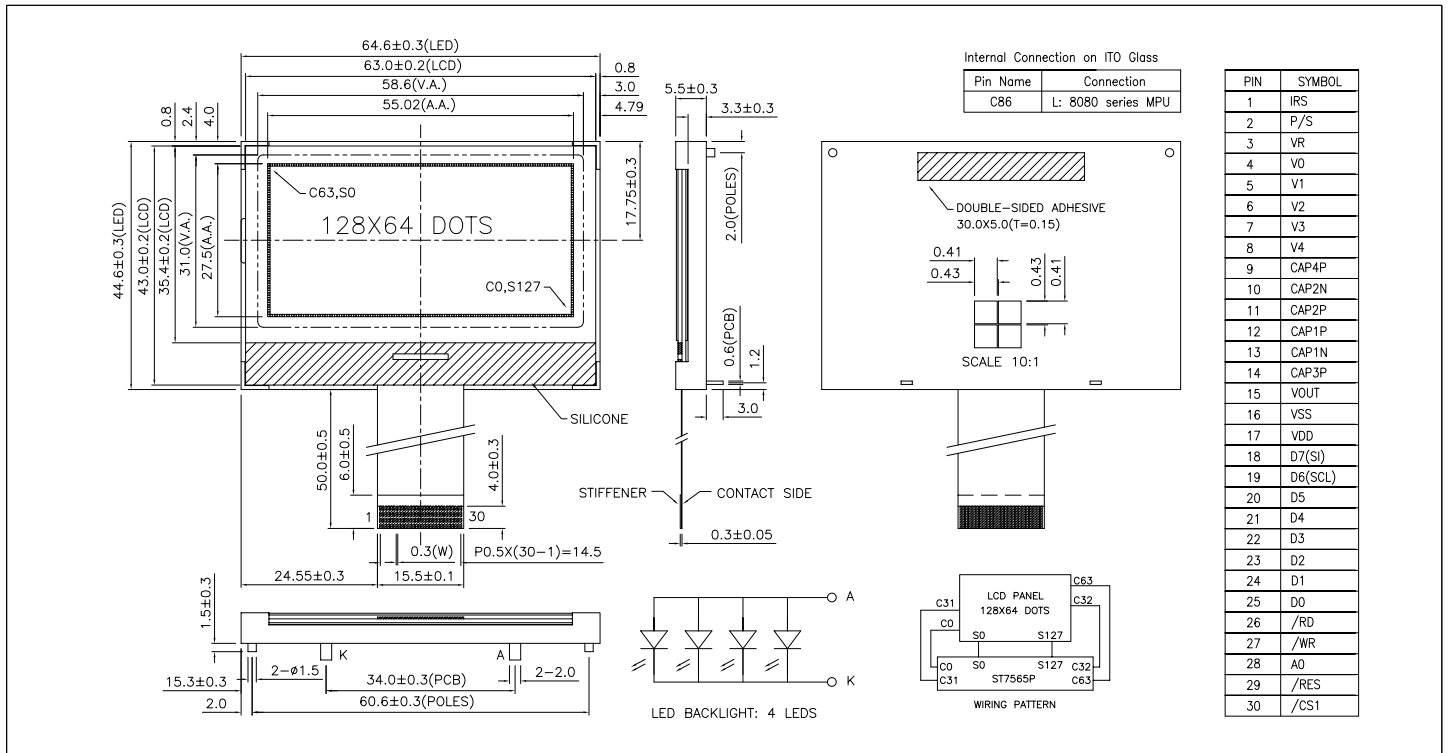

ABSOLUTE MAXIMUM RATINGS

Item	Symbol	Min.	Max.	Unit
Supply Voltage(Logic)	V _{DD} - V _{SS}	-0.3	3.6	V
Supply Voltage(LCD)	V _{OUT} - V _{SS}	-0.3	14.5	V
Input Voltage	V _I	-0.3	V _{DD} + 0.3	V
Operating Temp.	T _{opr}	-20	70	°C
Storage Temp.	T _{stg}	-30	80	°C

MECHANICAL DATA

Item	Nominal Dimensions	Unit
Module Size (W x H x T)	64.6 x 44.6 x 8.5	mm
Viewing Area (W x H)	58.6 x 31.0	mm
Dot Pitch (W x H)	0.43 x 0.43	mm
Dot Size (W x H)	0.41 x 0.41	mm
Weight	Approx. 22	g

ELECTRICAL CHARACTERISTICS (V_{DD}=2.4V to 3.3V)

Item	Symbol	Test Condition	Min.	Typ.	Max.	Unit
Input High Voltage	V _{IH}	--	0.8V _{DD}	--	V _{DD}	V
Input Low Voltage	V _{IL}	--	0	--	0.2V _{DD}	V
Output High Voltage	V _{OH}	I _{OH} = -0.1mA	0.8V _{DD}	--	V _{DD}	V
Output Low Voltage	V _{OL}	I _{OL} = 0.1mA	0	--	0.2V _{DD}	V
Supply Current	I _{DD}	V _{DD} = 3.0V	--	0.5	1.2	mA
LCD Driving Voltage	V ₀ - V _{SS}	T _a =25°C	--	9.0	--	V

PIN CONNECTIONS

Pin	Symbol	Level	Function
1	IRS	H/L	H: Use internal resistors for booster L: Use external resistors for booster
2	P/S	H/L	H: Parallel mode L: Serial mode
3	VR	--	V ₀ voltage adjustment terminal
4-8	V ₀ -V ₄	--	Power supply for LCD drive
9	CAP4P	--	Capacitor 4 positive connection
10	CAP2N	--	Capacitor 2 negative connection
11	CAP2P	--	Capacitor 2 positive connection
12	CAP1P	--	Capacitor 1 positive connection
13	CAP1N	--	Capacitor 1 negative connection
14	CAP3P	--	Capacitor 3 positive connection
15	V _{OUT}	--	DC/DC voltage converter output
16	V _{SS}	0V	GND
17	V _{DD}	2.4-3.3V	Power supply for logic and booster
18-25	D ₇ -D ₀	H/L	Data bus
26	/RD	L	Read signal. Active "L"
27	/WR	L	Write signal. Active "L"
28	A ₀	H/L	H: Display data L: Instruction code
29	/RES	L	Reset signal. Active "L".
30	/CS1	L	Chip selection signal. Active "L".

BLOCK DIAGRAM

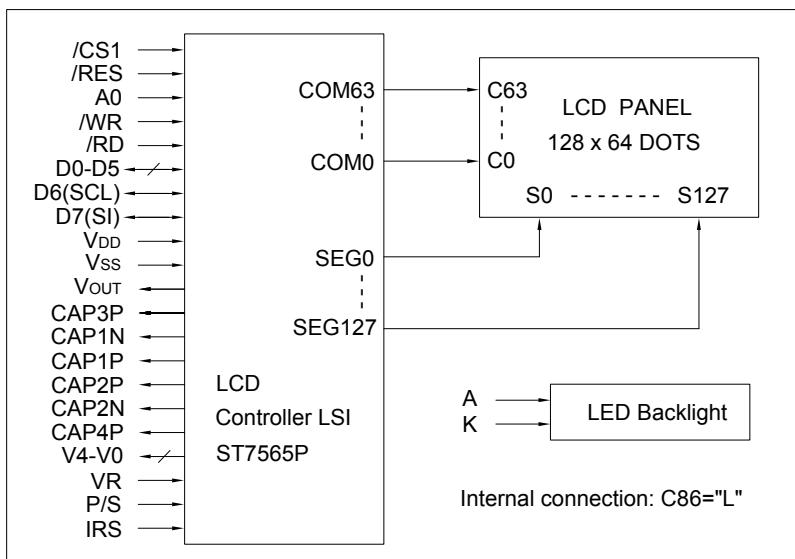

LED BACKLIGHT SPECIFICATIONS (T_a=25°C)

Item	Symbol	Typ.	Max.	Unit
Forward Voltage	V _f	2.9	3.1	V
Forward Current	I _f	30	--	mA
LED Color		White		