

ABSOLUTE MAXIMUM RATINGS

Item	Symbol	Min.	Max.	Unit
Supply Voltage(Logic)	V _{DD} - V _{SS}	-0.3	3.6	V
Supply Voltage(LCD)	V _{OUT} - V _{SS}	-0.3	14.5	V
Input Voltage	V _I	-0.3	V _{DD} + 0.3	V
Operating Temp.	T _{opr}	-20	70	°C
Storage Temp.	T _{stg}	-30	80	°C

MECHANICAL DATA

Item	Nominal Dimensions	Unit
Module Size (W x H x T)	51.0 x 38.0 x 8.5	mm
Viewing Area (W x H)	46.0 x 26.0	mm
Dot Pitch (W x H)	0.345 x 0.36	mm
Dot Size (W x H)	0.315 x 0.33	mm
Weight	Approx. 15	g

ELECTRICAL CHARACTERISTICS (V_{DD}=3.0V to 3.3V)

Item	Symbol	Test Condition	Min.	Typ.	Max.	Unit
Input High Voltage	V _{IH}	--	0.8V _{DD}	--	V _{DD}	V
Input Low Voltage	V _{IL}	--	0	--	0.2V _{DD}	V
Output High Voltage	V _{OH}	I _{OH} = -0.1mA	0.8V _{DD}	--	V _{DD}	V
Output Low Voltage	V _{OL}	I _{OL} = 0.1mA	0	--	0.2V _{DD}	V
Supply Current	I _{DD}	V _{DD} = 3.0V	--	0.5	1.0	mA
LCD Driving Voltage	V ₀ - V _{SS}	T _a =25°C	--	9.6	--	V

PIN CONNECTIONS

Pin	Symbol	Level	Function
1	NC	--	No connection
2	/CS1	L	Chip selection signal. Active "L".
3	/RES	L	Reset signal. Active "L".
4	A0	H/L	H:Display data L:Instruction code
5	/WR	L	Write signal. Active "L".
6	/RD	L	Read signal. Active "L".
7-12	D0-D5	H/L	P/S=H: D0 to D7 are 8-bit data bus.
13	D6(SCL)	H/L	P/S=L: D6 is serial clock input;
14	D7(SI)	H/L	D7 is serial data input.
15	V _{DD}	3.0-3.3V	Power supply for logic and booster
16	V _{SS}	0V	GND
17	V _{OUT}	--	DC/DC voltage converter output
18	CAP3P	--	Capacitor 3 positive connection
19	CAP1N	--	Capacitor 1 negative connection
20	CAP1P	--	Capacitor 1 positive connection
21	CAP2P	--	Capacitor 2 positive connection
22	CAP2N	--	Capacitor 2 negative connection
23-27	V4-V0	--	Power supply for LCD drive
28	P/S	H/L	H: Parallel mode L: Serial mode

BLOCK DIAGRAM

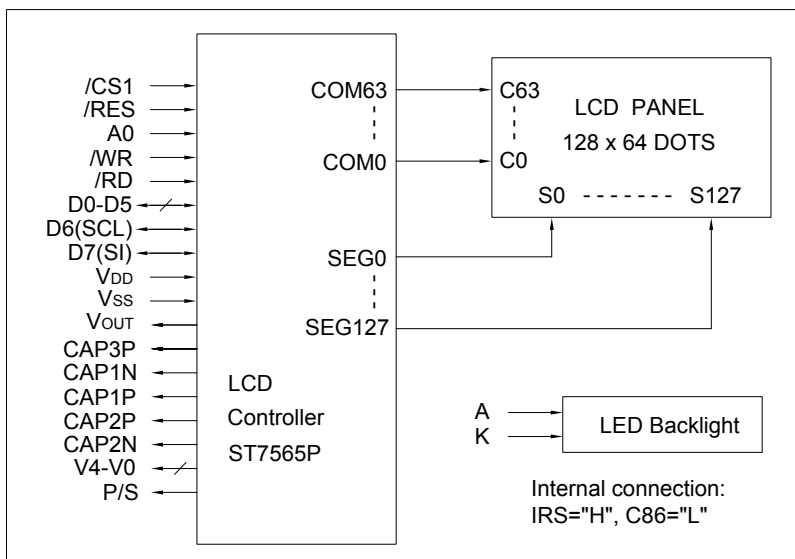

LED BACKLIGHT SPECIFICATIONS (T_a=25°C)

Item	Symbol	Typ.	Max.	Unit
Forward Voltage	V _f	2.9	3.1	V
Forward Current	I _f	20	--	mA
LED Color		White		