

ABSOLUTE MAXIMUM RATINGS

| Item | Symbol | Min. | Max. | Unit |
|-----------------------|-----------------------------------|------|-----------------------|------|
| Supply Voltage(Logic) | V _{DD} - V _{SS} | -0.3 | 5.25 | V |
| Supply Voltage(LCD) | V _O - V _{SS} | -0.3 | 7.0 | V |
| Input Voltage | V _I | -0.3 | V _{DD} + 0.3 | V |
| Operating Temp. | T _{opr} | -20 | 70 | °C |
| Storage Temp. | T _{stg} | -30 | 80 | °C |

MECHANICAL DATA

| Item | Nominal Dimensions | Unit |
|---------------------------|--------------------|------|
| Module Size (W x H x T) | 93.0 x 70.0 x 13.5 | mm |
| Viewing Area (W x H) | 72.0 x 39.0 | mm |
| Dot Pitch (W x H) | 0.52 x 0.52 | mm |
| Dot Size (W x H) | 0.48 x 0.48 | mm |
| Weight | Approx. 75 | g |

ELECTRICAL CHARACTERISTICS (V_{DD}=5V±0.15V)

| Item | Symbol | Test Condition | Min. | Typ. | Max. | Unit |
|---------------------|----------------------------------|--------------------------|--------------------|------|-----------------|------|
| Input High Voltage | V _{IH} | -- | 0.7V _{DD} | -- | V _{DD} | V |
| Input Low Voltage | V _{IL} | -- | -0.3 | -- | 0.6 | V |
| Output High Voltage | V _{OH} | I _{OH} = -0.1mA | 0.8V _{DD} | -- | V _{DD} | V |
| Output Low Voltage | V _{OL} | I _{OL} = 0.1mA | 0 | -- | 0.4 | V |
| Supply Current | I _{DD} | V _{DD} = 5.0V | -- | 3.0 | 5.0 | mA |
| LCD Driving Voltage | V _O - V _{SS} | T _a =25°C | -- | 6.2 | -- | V |

PIN CONNECTIONS

| Pin | Symbol | Level | Function |
|-----|------------------|-------|---------------------------------|
| 1 | V _{SS} | 0V | GND |
| 2 | V _{DD} | +5V | Power supply for logic |
| 3 | V _O | -- | No connection |
| 4 | RS | H/L | H : Data L : Instruction code |
| 5 | R/W | H/L | H : Read L : Write |
| 6 | E | H,H→L | Enable signal |
| 7 | DB0 | H/L | Data bus |
| 8 | DB1 | H/L | |
| 9 | DB2 | H/L | |
| 10 | DB3 | H/L | |
| 11 | DB4 | H/L | |
| 12 | DB5 | H/L | |
| 13 | DB6 | H/L | |
| 14 | DB7 | H/L | |
| 15 | PSB | H/L | H: Parallel mode L: Serial mode |
| 16 | NC | -- | No Connection |
| 17 | /RST | L | Reset signal. Active "L". |
| 18 | V _{OUT} | -- | No connection |
| 19 | LEDA | +5V | Power supply for LED backlight |
| 20 | LEDK | 0V | |

BLOCK DIAGRAM

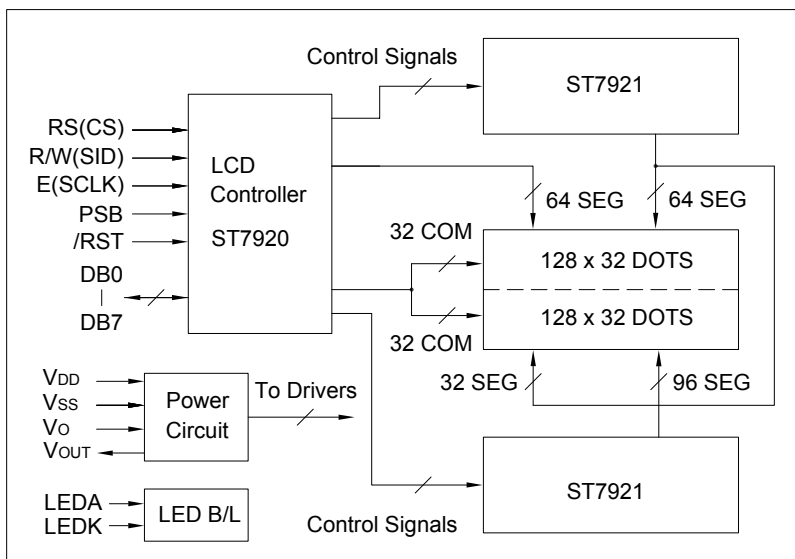

LED BACKLIGHT SPECIFICATIONS (T_a=25°C)

| Item | Symbol | Typ. | Max. | Unit |
|-----------------|----------------|-------|------|------|
| Forward Voltage | V _f | 3.1 | 3.3 | V |
| Forward Current | I _f | 45 | -- | mA |
| LED Color | | White | | |